

ECOUSTIC® TORQUE CEILING TILE



unika vaev
IN STYLE

Hear yourself think®

ECOUSTIC® COLORS



AQUA



ARCTIC



AUBERGINE



BALTIC

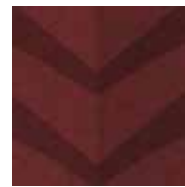

BERRY



CAMEO



CAPER



CHARCOAL



COBALT



CREAM



DOVE



FIELD



FOSSIL



FRESCO



GREEN



HUNTER

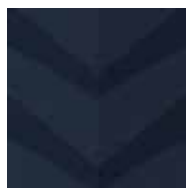

INDIGO

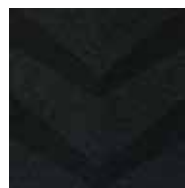

JET



LEMON



LIGHT GREY



LIME



LUNAR



MICA



NATURAL



NAUTICAL



OATMEAL



OPAL



ORANGE



OYSTER



PAPRIKA



PEWTER



QUARTZ



RED

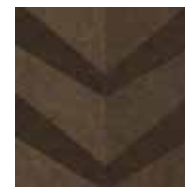

SEPIA



SKY



SPRAY



TAUPE



VAULT



WHITE



YELLOW

Patterns shown are not to scale
 Product may vary in color due to the nature of the media
 Please refer to website for current color range

ecoustic® global leaders
 by INSTYLE in acoustic
 products

ECOUSTIC® TORQUE CEILING TILE

**Front View
24 Tile**

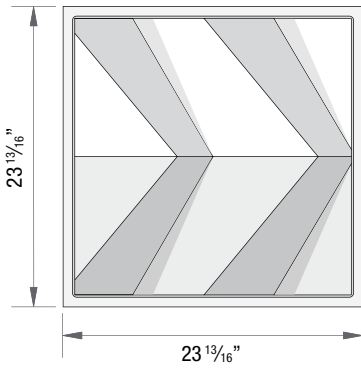

Side View

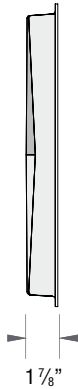

**Front View
48 Tile:**

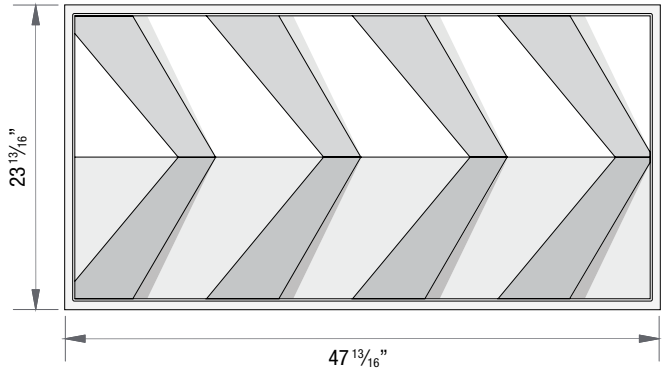

CONTENT 100% PET (up to 32.5% recycled)

DIMENSIONS 24 Tile- 23.8" (w) x 23.8" (h) x 1.9" (d)
(605mm x 605mm x 48mm)
48 Tile- 47.8" (w) x 23.8" (h) x 1.9" (d)
(1215mm x 605mm x 48mm)
Drops into existing T-Frame suspended ceiling systems with a nominal 24" x 24" or 48" x 24" grid.

APPLICATION Ceiling

FIRE RATINGS

AS/ISO 9705
GB 8624
1S05660.1

ACOUSTIC NRC 0.80

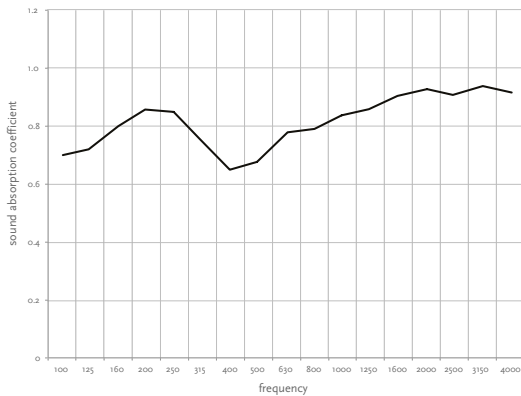

PLEASE NOTE It is the responsibility of site installation managers to confirm compatibility between the ceiling grid system specified and the dimensions of Ecoustic® ceiling tiles prior to placement of purchase order. Custom sized Ecoustic® ceiling tiles can be produced, however, conditions do apply. Please contact Unika Vaev customer service or your local sales representative for more information.

unikavaev.com
800-237-1625

- Environment:**
- California 01350 Emissions Compliant
 - Low VOC
 - Recycled Content
 - Rapidly Renewable Content
 - mindful MATERIALS
 - Greentag Level A Certified
 - Health Product Declaration®
 - Declare Compliant
 - Prop 65 Compliant
 - No FR Additives
 - NO Conflict Minerals

Building Rating Systems: Torque will contribute the following points for Green Star, LEED + WELL building standards.

Criteria	Green Star	LEED	WELL
Recycled content	yes	yes	no
Low-VOC	yes	yes	yes
EPD	yes	yes	no
3rd Party Greentag Level A Certification	yes	yes	yes
Toxic Material Reduction	no	no	yes



ecoustic® global leaders
by INSTYLE in acoustic products

ECOUSTIC® TORQUE CEILING TILE

Moisture Absorption: Exposure to an atmosphere of 50% and 95% RH for four days provides moisture absorption of less than 0.2% per volume. As Ceiling Matrix is 100% polyester, it will not degrade over time due to moisture, mildew or rot in office environments.

Fixtures: Any fixtures must be supported independent to the Ecoustic® Torque Ceiling tile. Ecoustic® Torque Ceiling tile can be cut on site to accommodate for new and existing lighting and fixtures. When cutting use a new blade for each cut and ensure the area to be cut is fully supported throughout. Cut from the tile face with care.

HVAC: Ensure Ecoustic® Torque Ceiling tile is compliant with the specified HVac system. Ecoustic® Torque Ceiling tile is recommended for Ducted Return Air and is not Plenum Return air rated.

Back Loading: Ecoustic® Torque Ceiling tile is not suitable for back loading. Loads must be supported independently by the grid or through the use of additional fixtures.

Toxicity: Polyester is nontoxic and is classed the same as wood under the state of New York article 15 Part 1120. Ecoustic® Torque Ceiling tile does not contain any Red list chemicals (USA EPA).

ECOUSTIC® TORQUE CEILING COMPONENTS

